

DOW Series

Installation Instructions

SAFETY INSTRUCTIONS

1. Read all safety precautions and installation instructions carefully before installing or servicing this fixture. Failure to comply with these instructions could result in potentially fatal electric shock and/or property damage.
2. It is recommended that a qualified electrician perform all wiring. This fixture must be wired in accordance with all national and local electrical codes.
3. Do not handle any energized fixture or attempt to energize any fixture with wet hands or while standing on a wet or damp surface or in water.
4. This fixture is designed for use in a 120VAC, 60Hz fused circuit. This fixture is not compatible with dimming circuit.
5. Make sure that the power source conforms to the requirements of the fixture. (See labels on the fixture housing).
6. To reduce the risk of electrical shock, and to assure proper operation, this fixture must be adequately grounded. To accomplish proper grounding, there must be a separate ground wire (green) contact between this fixture and the ground connection of your main power supply panel.
7. This fixture is intended to be used for general outdoor lighting in dry, damp or wet locations. For wet location, fixture must be mounted at least 48 inches above ground level.
8. Disclaimer

Changes or modifications not expressly approved by the party responsible for compliance could void the user's authority to operate the equipment. NOTE: This equipment has been tested and found to comply with the limits for a Class B digital device, pursuant to Part 15 of the FCC Rules and Canadian ICES-005 (B) / NMB-005 (B). These limits are designed to provide reasonable protection against harmful interference in a residential installation. This equipment generates, uses and can radiate radio frequency energy and, if not installed and used in accordance with the instructions, may cause harmful interference to radio communications. However, there is no guarantee that interference will not occur in a particular installation. If this equipment does cause harmful interference to radio or television reception, which can be determined by turning the equipment off and on, the user is encouraged to try to correct the interference by one or more of the following measures:

- Reorient or relocate the receiver antenna.
- Increase the separation between the equipment and receiver.
- Connect the equipment into an outlet on a circuit different from that to which the receiver is connected.
- Consult with the dealer or an experienced radio/TV technician for help.

Any modifications to this fixture may void the warranty and interfere with the safe operation of the luminaire. Operation is subject to the following two conditions: (1) this device may not cause interference, and (2) this device must accept any interference, including interference that may cause undesired operation of the device.

NEEDED TOOLS

- Safety Glasses
- Ruler/Tape Measure
- Flat Blade Screwdriver
- Phillips Screwdriver
- Adjustable Wrench
- Drill
- 3/16" Drill Bit
- 3/32" Drill Bit
- Pliers

ASSEMBLY INSTRUCTIONS

Step 1 – Preparing for installation

- A. Disconnect electrical power at fuse or circuit breaker box before installing or servicing any part of this fixture.
- B. Carefully remove the fixture from the carton.
- C. Remove mounting bracket (1) from the fixture.

DOW Series Installation Instructions

- D. Install mounting bracket (1) on the junction box (not included) by securing it with two screws (2).
- E. Feed the black, white, and green supply wires into the fixture through the opening of the mounting bracket.

Wiring – All wiring must take place inside junction box (not included)

Caution: Make sure power is off at fuse or circuit breaker box. Check power wires for damage or scrapes. If the power supply wires are within three inches of the driver, use a wire suitable for at least 90°C (194F). **Note:** Most dwellings built before 1985 have supply wire rated to 60°C. Consult a qualified electrician to ensure correct branch circuit conductor before installing.

Step 2 – Wiring fixture

- A. Make all wire connections to appropriate wire. Secure with wire nuts (provided).
- B. Connect the green wire from the fixture to the supply power source ground wire.
- C. Connect the black wire from the fixture to the black (L) wire from supply power source.
- D. Connect the white wire from the fixture to the white (N) wire from supply power source.
- E. Do not mix wires. Pull on each wire lead to make sure connections are secure. Make certain no bare wires are exposed outside of wire connectors. Tuck all connections neatly into the junction box.

Step 3 – Mounting

- A. Install fixture (4) over the mounting bracket (1) by aligning two holes on the inside to studs (3) and secure with two screws (5).

Step 4 – For wet location

- A. Apply a small amount of silicone (not included) per manufacturer’s recommendation around the perimeter of the fixture (4) where it contacts with the surface of the wall but not on the bottom.

Step 5 – Restore power at fuse or circuit breaker box

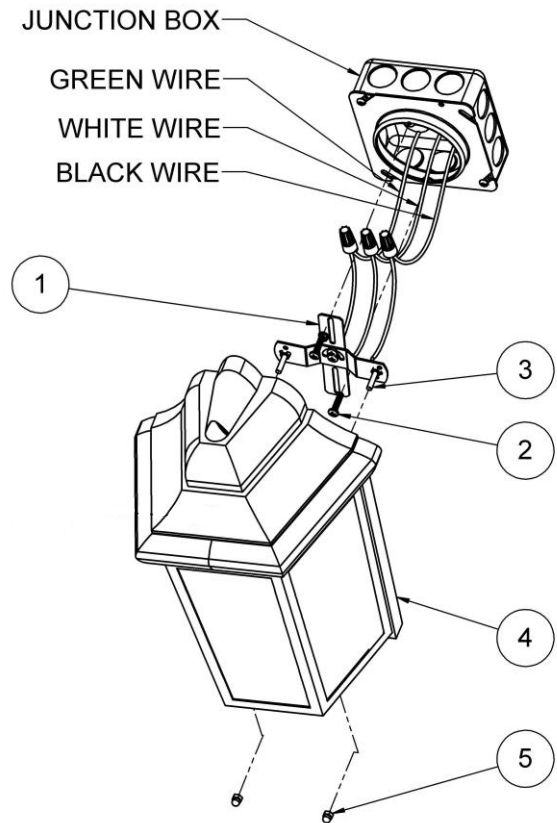

IMPORTANT SAFE PRACTICES

Color Changing Temperature Adjustment, CCT (if desired).

- 1. Adjust CCT switches on each board accordingly to the desired color temperature as seen below. All boards must be set the same way.
Note: Fixture is preset to 3000K from factory. Power to fixture must always be turned OFF prior to adjusting CCT switches.

COLOR TEMPERATURE ADJUSTMENT SETTING

